

Oct. 7, 1952

M. S. BAKER ET AL

2,612,867

FOUNTAIN PEN

Filed Aug. 23, 1948

2 SHEETS—SHEET 1

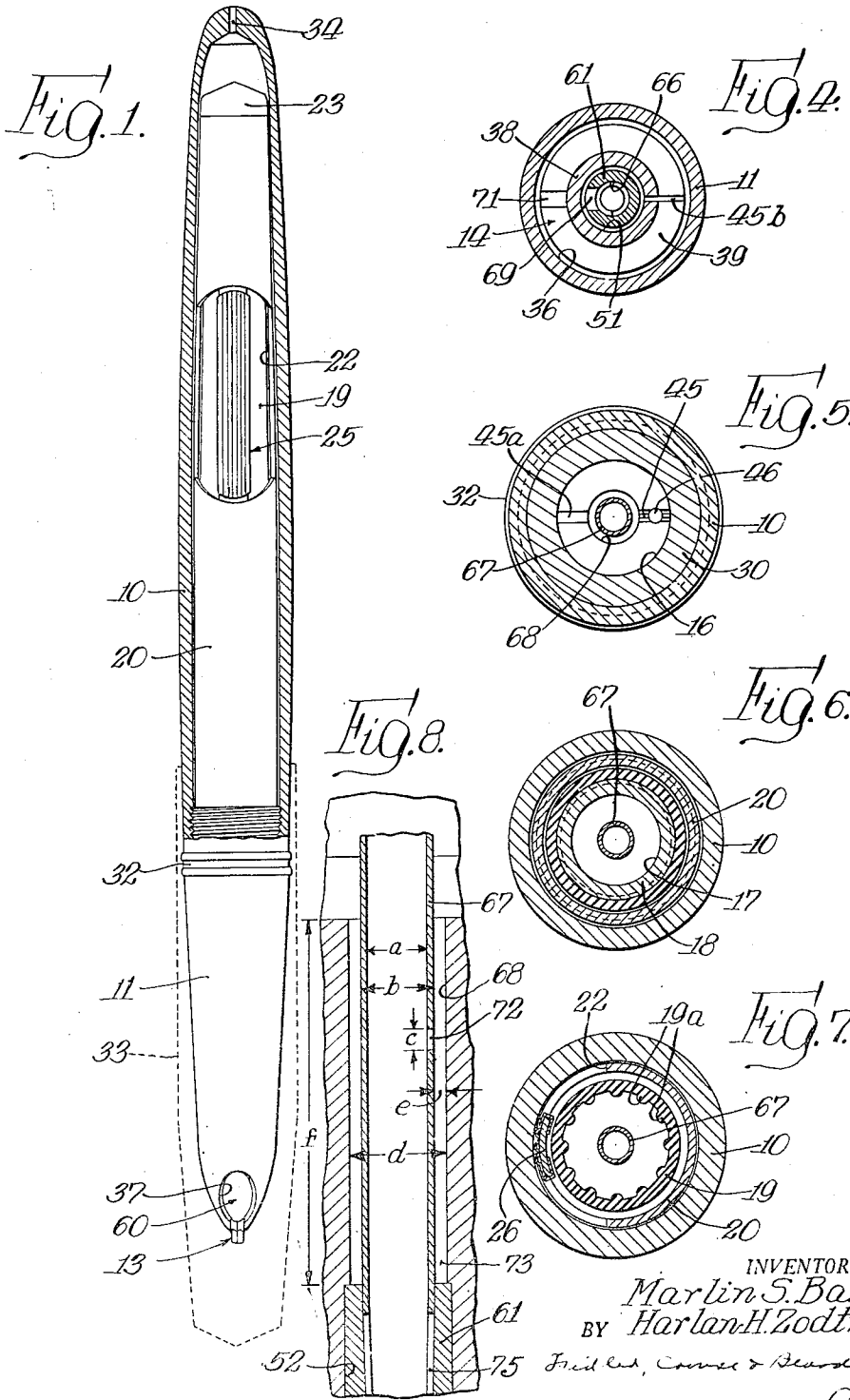

INVENTORS.
Marlin S. Baker,
BY *Harlan H. Zodtner,*
Friedrich, Conner & Rensselaer
Attys.

Oct. 7, 1952

M. S. BAKER ET AL

2,612,867

FOUNTAIN PEN

Filed Aug. 23, 1948

2 SHEETS—SHEET 2

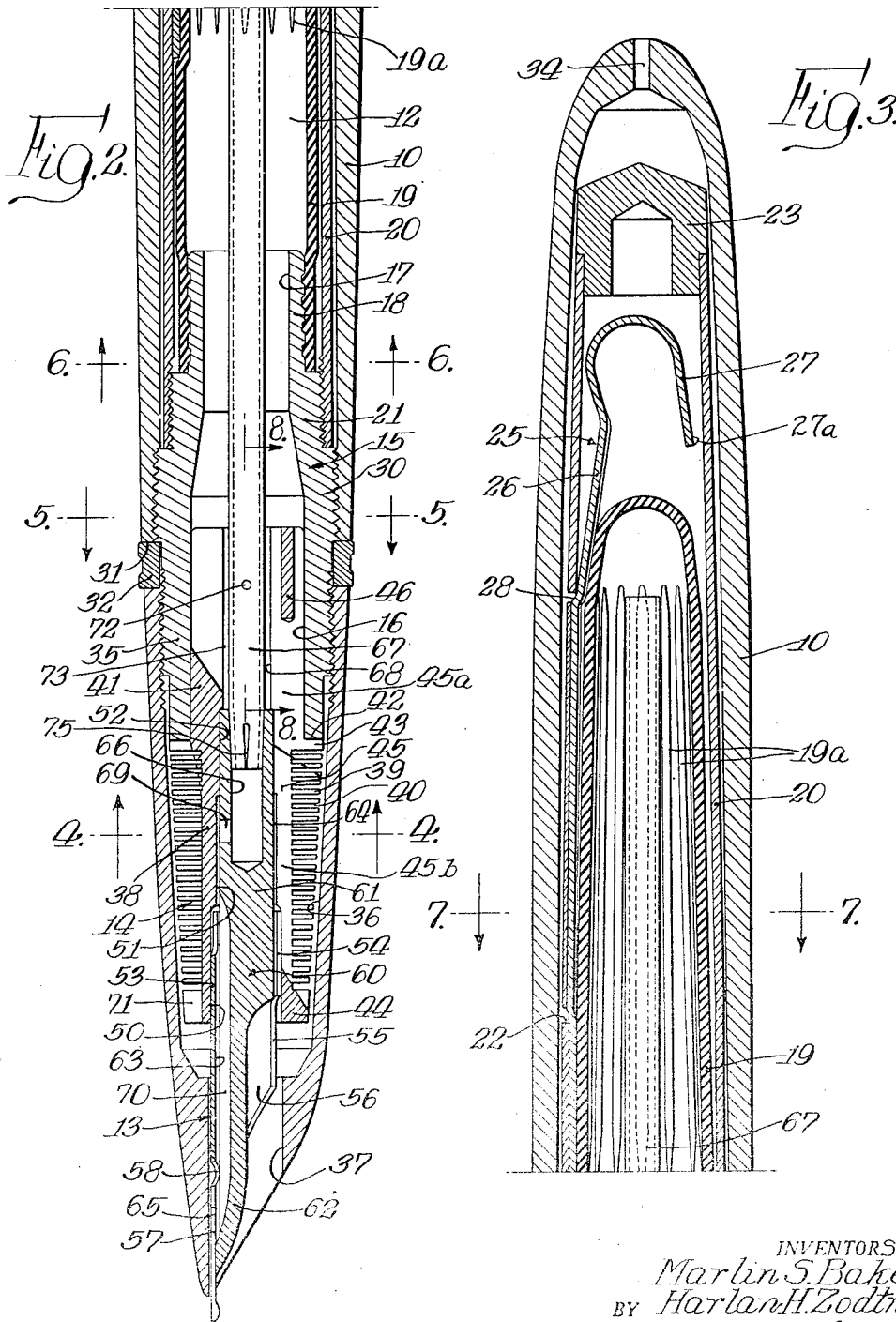

INVENTORS.
Marlin S. Baker,
BY Harlan H. Zodtner.
Fidler, Cooney & Bursley
Attys.

UNITED STATES PATENT OFFICE

2,612,867

FOUNTAIN PEN

Marlin S. Baker and Harlan H. Zodtner,
Janesville, Wis., assignors to The Parker
Pen Company, Janesville, Wis., a corpora-
tion of Wisconsin

Application August 23, 1948, Serial No. 45,776

8 Claims. (Cl. 120-46)

1

This invention relates generally to fountain pens and has to do particularly with a filling mechanism therefor of the type embodying a breather tube.

An object is to provide a fountain pen having a multiple stroke filling means embodying a new and improved breather tube construction.

Another object is to provide a fountain pen having a multiple stroke filling means of improved construction by which the ink reservoir may be filled to maximum capacity with a minimum number of filling strokes.

Another object is to provide a fountain pen of the multiple stroke filling type having a breather tube so constructed and arranged that it facilitates the flow of ink into the reservoir upon each stroke of the filling means and thereby contributes to increased efficiency of the filling means.

A further object is to provide a fountain pen having a breather tube of such construction that a relatively small quantity of ink is expelled from the pen upon each compression stroke thereby insuring maximum expulsion of air from the reservoir and consequently a maximum intake of ink upon each suction stroke.

Another object is to provide a fountain pen of the type employing a breather tube, which pen embodies a new and improved arrangement for venting through the forward end of the breather tube the air space at the forward end of the ink reservoir, thereby to prevent expulsion of ink from the pen upon an increase in pressure of the air in the ink reservoir or decrease in the pressure of the surrounding atmosphere.

Another object is to provide multiple stroke filling means having a breather tube which is vented in its forward portion but which is so constructed and arranged that a minimum quantity of air is forced through the vent and back into the reservoir during each compression stroke in the filling operation thereby insuring that a maximum proportion of the air displaced during the compression stroke is expelled from the pen and a maximum quantity of ink is drawn into the pen during the suction stroke.

Other objects will appear from the following description taken in connection with the appended drawings, wherein:

Figure 1 is a bottom plan view of a fountain pen constructed in accordance with the invention with certain of the parts broken away and sectioned;

Fig. 2 is a longitudinal sectional view taken through the forward portion of the pen of Fig. 1;

2

Fig. 3 is an enlarged longitudinal sectional view taken through the rearward portion of the pen of Fig. 1;

Fig. 4 is an enlarged transverse sectional view taken along line 4-4 of Fig. 2;

Fig. 5 is an enlarged transverse sectional view taken along line 5-5 of Fig. 2;

Fig. 6 is an enlarged transverse sectional view taken along line 6-6 of Fig. 2;

Fig. 7 is an enlarged transverse sectional view taken along line 7-7 of Fig. 3; and

Fig. 8 is an enlarged, fragmentary view of a portion of the structure of Fig. 2.

For the purpose of illustrating the present invention it is disclosed in connection with a fountain pen generally similar to that disclosed in the co-pending application of Kenneth Parker and Ivan D. Tefft, Serial No. 45,624, filed August 23, 1948, for Fountain Pen, to which pen the present invention is excellently well adapted. However, it will be understood that the present invention is not limited to the details of the fountain pen shown and described herein but is excellently adapted for embodiment in fountain pens of other forms. For example, the novel breather tube arrangement of our invention may be embodied in other types of multiple stroke filling devices and including other arrangements for effecting displacement of air from the reservoir. Also our breather tube arrangement may be employed with other types of feed means than that disclosed herein although it is especially effective when combined with a feed of the general type illustrated.

Referring now particularly to Figs. 1 and 2, the pen includes a casing or housing formed by a barrel 10 and a forwardly extending hollow shell 11 which together surround and substantially inclose the internal members of the pen. The shell and barrel preferably are formed of a suitable known plastic. The pen is provided interiorly with an ink reservoir 12, a writing point or nib 13 (the extreme tip of which projects from the shell 11), and a feed means connected between the ink reservoir 12 and the writing nib for feeding ink to the latter, which feed means preferably includes an ink governor or overflow collector 14 for controlling the feed of ink, all of which elements are more fully described hereinafter.

A tubular body, which preferably takes the form of an externally threaded bushing or nipple 15, is provided for connecting a majority of the other members forming the pen and for retaining them in proper assembled relationship. The body 15, preferably formed of a suitable plastic,

is provided with a forward bore 16 and a rearward bore 17, which may be smaller than the forward bore, and is formed with a plurality of different external diameters providing in effect a plurality of longitudinally displaced sections of different diameters adapted to receive various of the pen members as hereinafter described. The reservoir 12 is defined by the rearward bore portion 17 of the body 15 and by an elongate, flexible and resilient sac 19 having its forward open end receiving the reduced section 18. The sac 19, together with the rearward portion of the body 15 thus defines an ink reservoir of substantial capacity. In forming the sac preferably the forward open end is of somewhat smaller diameter than the remaining portion of the sac so that such reduced portion is stretched when applied to the section 18 and a tight gripping action of the sac on the section 18 is provided. While the sac 19 may be retained on the section 18 merely by its resilience, preferably it is secured to the section 18 as by fusing it thereto or by a known cement.

The sac 19 is formed of suitable material of sufficient resilience to remain in expanded condition except when forcibly compressed. The material is resistant to inks of the types commonly used, that is, both acid and alkaline inks and will not deteriorate or lose its resilience over a long period of use. Preferably, the sac is formed of material which is transparent or sufficiently translucent to permit the user to observe the level of ink therein as hereinafter explained. The sac is adapted to be alternately compressed and released to draw ink into the reservoir for filling the latter in a manner which will be understood as the description proceeds. The sac 19 may be provided with a plurality of spaced, longitudinally extending ribs 19a which project inwardly from the inner wall thereof and which effectively stiffen the sac to aid it in returning rapidly to its initial shape after compression and subsequent release of the compressive force.

For the purpose of protecting the sac 19 when the barrel 10 has been removed for the filling operation (as hereinafter explained) in order to prevent accidental compression of the sac, a guard 20 is provided. The guard 20 is formed as an elongate hollow member open at its forward end and is telescoped over the sac 19 and the rearward end of the body 15. The open forward end of the guard 20 is secured to an intermediate section 21 of the body 15 of slightly greater diameter than the section 18. While the guard 20 may be secured in any suitable manner, it preferably is threaded onto the section 21 for convenience in assembly, although, it may if desired, be secured in other ways, as for example, by providing an annular groove (not shown) in the section 21 and spinning the material of the guard into such groove.

The guard 20 is provided with an opening 22 to expose a portion of the sac 19 and to provide access thereto so that the sac may be compressed by the user. The finger opening 22 preferably is of such longitudinal and circumferential extent as to permit the sac to be compressed and collapsed to a substantial extent as hereinafter explained more in detail. The rearward end of the guard 20 is closed as by a button or plug 23 preferably formed of a plastic, and which serves to stiffen and reinforce the end portion of the guard 20 to prevent damage thereto such as might otherwise result should the

end be struck against another object or squeezed tightly by the fingers of the user.

The guard 20 preferably is formed of thin-walled material of suitable rigidity, and preferably a material which is relatively light in weight, and for this purpose preferably aluminum is employed, although other materials may be used. The guard 20 is disposed close to but spaced from the sac 19 and in turn is disposed close to but spaced from the barrel 10 thus permitting the sac 19 to be of relatively large diameter without substantially increasing the overall diameter of the pen barrel 10. However, the spaces between the guard and the sac and between the guard and the barrel, respectively, provide dead air spaces which serve to insulate the contents of the sac from external heating effects such as the heat of the hand of the user. In addition, the external surface of the guard preferably is polished to provide a reflecting surface which reflects radiant heat. Accordingly, the contents of the sac are protected against sudden increases in pressure which might otherwise result from external heating effects and which might tend to force ink from the pen.

The sac may be compressed manually or by suitable mechanism but preferably a pressure bar 25 is provided for compressing the sac 19 to a greater extent than would be conveniently possible were the sac compressed by direct engagement between fingers of the user. The pressure bar is so formed that it extends over a substantial portion of the length of the sac and hence when the bar is depressed, it compresses a substantial portion of the sac and displaces a relatively large amount of air. The pressure bar preferably is formed of resilient material such as metal and includes a flat body portion 26 and a hook-shaped end portion 27, which latter engages and is held between the inner walls of the guard and serves both to provide the necessary resiliency and to hold the pressure bar in position in the guard 20. To aid in retaining the hooked end, it is provided with spaced small prongs 27a which bite into the wall of the guard. The bar 25 is formed with an offset portion 28 adapted to enter and seat in the finger opening 22 to aid in maintaining the pressure bar in position. In addition, the offset is of such depth that the upper surface of the portion of the pressure bar which is exposed through the opening 22 is substantially flush with the adjacent surface of the guard and is in a position for convenient engagement between fingers of the user.

The barrel 10 is formed as a hollow member having an open forward end and is adapted to be telescoped over the guard 20 and a portion of the body 15 and thereby to inclose the guard 20 and sac 19. The barrel 10 is detachably connected to the body 15 in order to permit ready removal for the purpose of providing access to the sac for the filling operation. To this end the barrel is threaded at its open end onto a section 30 of the body 15 of slightly larger diameter than the section 21. The barrel 10 is adapted to be screwed onto the body 15 with its forward limit of movement being determined by abutment of the end edge of the barrel 10 against a rearwardly facing shoulder 31 provided for this purpose. The rearwardly facing shoulder 31 may be provided conveniently by a portion of the rear face of a clutch ring 32 carried on the body 15 and securely retained in position thereon. The clutch ring 32 also may serve to retain a slip cap 33 in a manner

generally similar to that disclosed and claimed in United States Letters Patent No. 2,278,907, granted April 7, 1942, to Marlin S. Baker.

The barrel 10 is provided with a vent opening 34, preferably located at its rear end, which maintains the air within the barrel and externally of the sac at atmospheric pressure. Therefore, no sudden change in the pressure of the air which is in the space within the barrel and surrounding the sac takes place when the barrel is moved into position surrounding the guard or is removed therefrom. Moreover, since the interior of the barrel is continuously vented to atmosphere, there is no possibility of a pressure differential being established between the air in the interior of the barrel and the atmosphere which might cause flooding or starving of the pen when used in writing or leakage during periods of non-use.

The hollow shell 11 is secured on the forward section 35 of the body 15, which preferably is of less diameter than the section 30. Preferably, the shell 11 is threaded onto the section 35 and abuts the clutch ring 32 to maintain it in firm abutment with the forward end of the section 30 of maximum diameter, the clutch ring being positioned on a portion of the body member 15 which is of the same diameter as the section 35 but preferably not threaded. The shell preferably is adhesively secured on the body 15 by a thermoplastic cement which may be softened by heat to permit removal of the shell for repair purposes. The shell is formed with a chamber 36 adapted to receive the governor 14, and a reduced bore 37 extending from the chamber 36 through the forward end of the shell 11, through which the nib 13 projects.

The governor or overflow ink collector 14 may be of any suitable form but preferably we employ a feed and governor of the general type disclosed and claimed in United States Letters Patent to Marlin S. Baker No. 2,223,541, granted December 3, 1940. The governor 14 is formed with a generally cylindrical body or core 38 having a plurality of longitudinally spaced, circumferential fins 39 extending radially therefrom and defining a plurality of circumferential, longitudinally spaced capillary spaces or cells 40. The capillary cells 40 are so formed that they progressively increase in width toward the forward end of the pen for controlling the flow of ink in a manner explained more in detail in said Baker Patent No. 2,223,541.

The governor 14 is formed with a shank portion 41 adapted to fit in the bore 16 for supporting the governor 14 on the body 15, with the forward core portion and fins being disposed in the chamber 36 and substantially filling the same. The governor 14 is positioned in the body 15 by a shoulder 42 provided by the rearwardmost fin 43 which fin, as well as the forwardmost fin 44, may be substantially thicker than the remaining intermediate fins 39 for the purpose of increasing their strength.

For the purpose of feeding ink from the reservoir 12, a capillary ink feed duct is provided which takes the form of a fissure 45 extending longitudinally of the governor 14 and radially inwardly throughout the radial extent of the fins 39 and the core 38. The feed duct 45 has a rearward portion 45a which opens at its rear end into the chamber defined by the bore 17 and extends forwardly to the rearward cells 40, and a forward portion 45b of narrower width which extends to short of the forward end of the governor 14. The feed duct 45 which preferably is disposed in the

bottom portion of the governor 14 and intersects the fins 39 and the capillary cells 40 defined thereby. Thus the capillary cells 40 are in feeding communication with the feed duct 45 and constitute a capillary overflow space constantly in feeding communication with the ink feed duct 45 to receive ink tending to flow through the latter in excess of that required for writing purposes. The thicker fins 43 and 44 serve to maintain the desired spacing of the opposed walls which define the feed duct 45 but, in order to aid in maintaining this spacing, a spacing pin 46 may be inserted in a suitable opening of the rearward end of the shank 41.

The governor 14 is formed with an axial bore extending throughout its length and communicating at its rear end with the chamber defined by the bore 16 and forming a portion of the ink reservoir. The bore in the governor 14 is formed with a plurality of portions 50, 51, 52 and 68 of progressively decreasing diameters respectively from the forward end of the collector 14 in a rearward direction. The forward bore portion 50 provides a socket for the writing nib 13 which preferably has a cylindrical shank portion 53 frictionally fitted into such socket. The shank portion 53 is slotted in its underside as at 54, and provided with a notch 55 forwardly for the slot to provide a passage for the entry of air into the reservoir, as hereinafter explained. The nib may, if desired, seat against the rear wall of the bore portion 50 in order to accurately position the nib longitudinally with respect to the associated pen members. The nib 13 has a forward tapered writing end portion 56 provided with a longitudinal slit 57 terminating rearwardly in a pierce 58, the nib being of such length that when seated in the bore portion 50 the writing tip projects slightly beyond the forward end of the bore 37.

Ink is delivered to the nib 13 by ink feed means connecting the nib slit 57 with the feed duct 45 in the collector 14 whereby ink is maintained constantly at the nib slit 57 and is available to replace ink withdrawn from the nib in writing. Such ink feed means includes a feed bar 60 associated with the nib 13 and formed with a generally cylindrical body portion 61 frictionally seated in the bore portion 52, and a reduced forward end portion 62 extending forwardly through the nib and providing with the adjacent wall of the bore 37 an air passage extending through the forward end of the shell 11 and communicating through the nib notch 55 with the chamber 36 in the shell 11. The feed bar 60 is of slightly smaller diameter than the interior of the nib 13, thereby providing between the nib and feed bar an arcuate capillary space 63 extending from the rear end of the nib to forwardly of the nib pierce 58. This arcuate space 63 communicates with an annular capillary ink space 64 defined by the bore portion 51 and the adjacent portion of the feed bar body 61, which space 64 is in communication with the ink feed duct 45. Thus it will be seen that an ink feed passage is provided which provides communication between the reservoir 12 and the nib pierce 58 and slit 57. This feed passage functions in a manner generally similar to that described in Baker Patent No. 2,223,541. However, in order to further insure that ink will be delivered by capillary action to the nib slit, an ink feed slit 70 of capillary width is provided in the feed bar. The slit extends longitudinally from adjacent the space 64 to adjacent the nib slit 57 and in alignment with the latter.

7

Preferably, the bore 37 is slightly relieved or recessed above the nib 13, as at 65, to provide an arcuate capillary space extending over the nib and which receives ink through the pierce 58 in order to insure that a quantity of ink is maintained at the nib slit and the pen, therefore, is always in condition for instant writing.

Air to replace ink withdrawn from the reservoir in writing is admitted to the ink reservoir 12 by way of the cells 40 and feed duct 45, as explained in Baker Patent No. 2,223,541, the governor 14 being provided with an air channel 71 (Fig. 4) in its top side, which channel is of greater than capillary width and extends throughout the length of the collector and in intersection with all of the fins 39 and capillary cells 40, preferably at a point substantially diametrically opposite the feed duct 45. The air channel 71 communicates with the chamber 36 and thus with the exterior of the shell 11 through the nib notch 55 and the bore 37.

For the purpose of providing for multiple stroke filling of the reservoir, a breather tube 67 of novel construction, arrangement and functioning is incorporated in the pen for performing functions generally similar to those of a conventional breather tube. Thus the breather tube 67 communicates at its forward end with the feed means and at its rear end with the interior of the reservoir. Thus air is displaced from the reservoir through the breather tube upon compression of the sac, and upon release of the sac a suction is created which draws ink into the sac. Thus upon repeated filling strokes, each consisting of compression and subsequent release of the sac, ink is drawn into the reservoir in successive increments to fill the reservoir.

The breather tube 67 is securely seated in a bore 66 in the feed bar body as by providing slits 75 in the end of the tube, and extends rearwardly through the bore 68 and into the reservoir 12 and terminates at its rear end close to the rear end of the sac 19. The bore 66 is connected through a transverse passage 69 with the annular ink space 64 previously described and thus an air discharge path is provided by the breather tube 67, bore 66, passage 69, annular space 64, arcuate ink space 63, the forward portion of feed duct 45, capillary cells 40 and air channel 71 through which air is displaced from the reservoir 12 during the filling operation as hereinafter described. The breather tube 67 is disposed axially of the body 15 and the sac 19 and, therefore, when the sac 19 is compressed and partially collapsed during the filling operation such manipulation does not bend or collapse the breather tube 67 and there is therefore no interference with the passage of air through the breather tube.

To fill the pen, the barrel 10 is unscrewed from the body 15 and is slid rearwardly to disassemble it from the remainder of the pen thereby to expose the finger opening 22 and render the pressure bar 25 accessible to the user. The forward end of the pen then is inserted in a supply of ink and the sac 19 repeatedly compressed as by repeated depression and release of the pressure bar 25. During the filling operation the pen may be held by grasping the shell at its rearward portion with one hand and by pressing on the pressure bar with the fingers of the other hand, but, owing to the provision of the rigid guard 20, the pen may be held solely by one hand and the sac compressed by the fingers of that hand. Upon each compression of the sac 19, air is displaced from the reservoir through the breather tube 67, 75

8

and the air discharge path above described, and thence through the front end of the shell. At the same time, some air is displaced from the reservoir through the rear end of the ink feed duct 45, capillary cells 40, and thence through the front end of the shell. Upon release of the pressure upon the sac, the latter returns to its normal expanded condition, whereby a suction action is produced which draws ink into the reservoir on a reverse direction along the path through which air was expelled during the compression stroke and principally through the breather tube. It will be understood that where any ink is in the pen at the beginning of the filling operation, some ink may be expelled with the air upon the first compression of the sac; also, ink may be expelled with the air upon subsequent compressions. However, the amount of ink drawn in during each expansion of the sac is greater than that expelled with the air during the previous compression and therefore repeated compression and release of the sac 19 fills the reservoir 12.

It will be understood that ink will rise in the reservoir until it stands at a level substantially even with the rear end of the breather tube. Thereafter, the only additional ink which can be drawn into the reservoir is an amount equal to that which is drawn in upon the next additional suction stroke. If further strokes are effected, no further ink will be drawn into the reservoir since upon each such additional compression stroke, ink instead of air is forced out of the pen and regardless of the number of such additional strokes, no more ink will be drawn in upon the expansion of the sac than is expelled during the compression of the sac. It will be noted, however, that the rear end of the breather tube extends to very close to the rear end of the sac so that the level of the ink at the end of the last effective filling stroke is very close to the rear end of the sac and the sac, therefore, is substantially filled.

Because the portion of the sac opposite the inner or rear end of the breather tube is exposed when the barrel is removed and the sac is transparent or translucent, the user may determine by inspection when sufficient ink has been drawn into the reservoir to raise the level of the ink to the level of the rearward end of the breather tube 67. The user thus is informed that the only further ink which will be drawn into the reservoir is that which will be drawn in by the next filling stroke and that only one such additional stroke is required to complete the filling operation. Thereafter the barrel is telescoped over the guard 20 and screwed home against the clutch ring 32 and the pen is ready for use.

In accordance with the present invention, the breather tube is made with a very small internal diameter and correspondingly small internal cross-sectional area. Therefore, only a relatively small quantity of ink stands in the breather tube at any time and which must be displaced when the sac is compressed during the filling operation to expel air from the reservoir through the breather tube. Thus, upon each compression stroke a relatively small proportion of the combined volume of ink and air which is expelled through the breather tube consists of ink and a relatively large proportion of such volume is air, with the result that upon each filling stroke there is only a comparatively small loss of efficiency because of the presence of ink in the breather tube.

Since the tube has a very small internal diameter, only a small quantity of ink is required to fill it. Therefore, the tube is completely filled by a small proportion of the ink drawn into the pen in each suction stroke and the remainder of the ink drawn in on such stroke enters the reservoir. Thus, a maximum quantity of ink enters the reservoir upon each suction stroke.

Since the breather tube 67 extends substantially to the rear end of the reservoir, the rear end of the breather tube is nearly always submerged in ink when the pen is held in point-up position, such as it usually is when carried in the pocket. Thus, any increase in the pressure of the air which is the space at the forward or upper end of the reservoir above the level of the ink, when the pen is in point-up position, or decrease in the pressure of the surrounding atmosphere (such as occurs when the pen is carried to high altitudes, as in airplane travel) may cause ink to be displaced through the breather tube and the feed and to leak from the pen. Therefore, we preferably vent the aforesaid space continuously when the pen is in point-up position by providing a vent 72 in the upper or forward end portion of the breather tube which vent leads into the interior of the upper end of the breather tube, which in turn communicates with the atmosphere through the air discharge path above described. The vent is located sufficiently close to the forward end of the breather tube so that it is always above the level of the ink and the reservoir is always vented when the pen is in point-up position even in cases where, as in the present embodiment, the rear end of the breather tube is located very close to the rear end of the reservoir and only a small quantity of air is present in the reservoir when the latter is filled to the maximum extent.

We have found that by forming the vent 72 of relatively small size, it is possible to reduce to a minimum the amount of air which is forced through the vent on the compression stroke of the sac and which represents a corresponding loss in effective capacity of each stroke inasmuch as such air is not expelled from the pen but is merely displaced from the breather tube through the vent and back to the reservoir. A further limitation on the loss of air through the vent 72 may be imposed by connecting the vent 72 with the reservoir by a restricted passage of such size and arrangement as will cause substantial turbulence of the air which tends to flow from the tube through the vent and thus restrict or prevent the flow of such air. The restricted passage may be conveniently constituted by locating the portion of the breather tube having the vent 72 within a trap or well 73 of relatively narrow wall-to-wall width. The well 73 extends in a direction generally perpendicular to the axis of the vent 72 and thus causes the air to flow at right angles to its direction of flow through the vent. In the present illustrative embodiment, the well 73 is defined by the bore portion 68 of the governor 14, the restricted passage being defined between the wall of such bore and the exterior wall of the breather tube 67. The well 73 is of such wall-to-wall width and the vent 72 is located sufficiently within the well so that when air is forced from the interior of the breather tube through the small diameter vent and into the well, sufficient turbulence is produced to cause restriction of the flow of air outwardly through the vent.

We have found that where a very small di-

ameter vent such as the vent 72 is provided in a breather tube formed of materials previously employed in the art, there is a tendency for a relatively strong film of ink to form and remain over the opening and effectively block or seal the opening against the passage of air there-through. Such sealing of the vent 72 has been found to interfere with the proper functioning of the vent when the pen is in point-up position. However, we have found that the formation and retention of a film across the opening 72 may be prevented by constructing the breather tube with surfaces which are highly wettable by inks of the character with which the pen is used, that is to say, thin, liquid inks. Where the surface of the breather tube adjacent the vent is of such highly wettable nature, ink tends to be drawn away from the vent and the formation and retention of a blocking or restrictive film across the vent is prevented. Moreover, we have found that the tendency for a film to form and remain over the vent 72 may further be decreased by constructing the breather tube of thin-walled material whereby the length of the passage through the walls forming the opening is very short relative to the diameter of the opening and the tendency for a film to form and remain is thereby reduced. To the foregoing ends, we form the breather tube from a material which is highly wettable by liquid inks and which material also permits the tube to be made with a very small wall thickness. We preferably employ a metal and we have found that silver is especially suitable. For best results, the silver should be of high purity (for example, in excess of 90% silver) and have clean surfaces. Other materials having the desired wetting characteristic may be employed but we prefer to use silver because of its numerous desirable qualities such as resistance to rust and corrosion, adequate mechanical strength, general suitability for manufacturing operations, and suitability for forming a small diameter thin-walled tube therefrom.

Where the vented end of the breather tube is disposed in a well having a narrow opening leading into the reservoir, such as in the case of the well 73, care must be taken that the size of the discharge opening is sufficiently large to prevent the formation of a film of ink there-across which would tend to seal such discharge opening and interfere with the proper operation of the vent 72. Therefore, in forming the well 73, it is necessary that the same be of sufficiently small wall-to-wall width to provide the necessary turbulence but at the same time the size of this opening must not be so small that a strong film will form across the discharge end.

The dimensions of the various members of the pen preferably are such that the maximum quantity of ink which may be present in those portions of the pen through which air must pass to vent the air space above the ink in the reservoir when the pen is in point-up position is less than the stand-by capacity of the governor. Therefore, should a pressure differential occur between the air in such space and the atmosphere, tending to force ink from those portions of the pen through which venting air must pass, such ink is drawn into the capillary cells of the governor and does not leak from the pen.

It has been noted that in the present invention a tendency is exhibited upon a fluctuation of the pressure differential between the interior of the reservoir and the atmosphere, for ink which is in the capillary cells of the governor,

except the rearward few cells thereof, to drain back into the reservoir when the pen is maintained in point-up position. By reason of this tendency, the governor tends to be cleared of ink when the pen is maintained in point-up position and has a large proportion of its ink storage capacity available as stand-by space for receiving ink should ink tend to flow from the reservoir in excess of that required for writing. Therefore, unless it is desired to use the pen in writing immediately after filling it, there is no necessity for clearing the collector in the course of the filling operation as the collector will tend to clear itself when the pen is held in point-up position as it customarily is when carried in the pocket. Where it is desired to write with the pen immediately after filling, the overflow ink storage spaces in the governor may be rapidly emptied of ink at the completion of the filling operation by removing the end of the pen from the supply of ink prior to the release of pressure upon the sac 19 after the last compression stroke. That is to say, when the user observes that the level of the ink has reached the height of the end of the breather tube, the sac is compressed an additional time and the pen is removed from the supply of ink, whereafter the pressure on the sac is released, which draws the ink from the overflow storage spaces into the reservoir. However, where the pen is to be carried in point-up position before being used, it generally is not necessary to perform such governor clearing operation because of the tendency for the governor to be cleared by drain-back.

In writing, ink finds its way from the reservoir 12 to the nib slit 57 by way of the feed duct 45, the annular ink space 64 and the feed slit 70, as well as the arcuate ink space 63; ink also enters the space 65 above the nib as above explained. Air enters the reservoir 12, for permitting ink to flow therefrom, by way of the air passage provided between the feed bar 60 and wall of the bore 37, the chamber 36, the air channel 71, the rearmost capillary cells 39, and the portion of the ink feed duct 45a rearwardly of the capillary cells. As will be understood from Baker Patent No. 2,223,541, the capillary cells receive ink which flows from the reservoir in excess of that required for writing purposes and fill with ink, thus blocking the flow of air to the reservoir 12 and preventing further ink from being withdrawn from the reservoir until the cells are emptied. The cells are emptied either by writing out the ink therefrom or by the establishment of pressure conditions which cause the ink to be drawn back into the reservoir from the cells. Because of the greater capillarity of the rearward cells these remain filled with ink until the remaining cells are emptied and thus the entry of air into the reservoir is blocked until substantially all of the cells have been emptied.

The sac 19 preferably is formed of a material which is relatively non-wettable (hydrophobic) by inks of the type with which the pen is to be used. Therefore there is substantially no tendency for ink to wet and adhere to the walls of the sac when the reservoir is depleted by writing. In addition the reservoir is formed without crevices or other formations in which ink would tend to remain. Thus, substantially all of the ink in the reservoir may be withdrawn when the pen is used in writing.

It is important that the dimensions of the

breather tube and associated members be carefully selected having in mind the above-described construction and arrangement of such elements and the necessary relationships therebetween. Excellent results were obtained in one practical embodiment of a fountain pen embodying our invention, which pen was generally similar in construction to the pen shown in the accompanying drawings and comparable in size to fountain pens of conventional construction, by forming the breather tube 67 (see Fig. 8) with an internal diameter *a* of approximately 0.036" and an external diameter *b* of approximately 0.046". The vent 72 in the aforesaid breather tube was formed with a diameter *c* of approximately 0.020" although it has been found that excellent results may be obtained where this dimension is within the range of from around 0.014" to around 0.026". In the aforesaid pen the well 75 had a diameter *d* of approximately 0.098", thus providing a wall-to-wall width *e* of approximately 0.026". This dimension may be varied somewhat but must be small enough to provide substantial turbulence and on the other hand, must be large enough to prevent the formation of a film of ink across the open end of the well. The vent 72 was located approximately midway of the depth *f* of the well although excellent results may be obtained where the vent is located anywhere between such midpoint and a point spaced $\frac{1}{8}$ " from the open end of the well where the well is formed with the above described diameter and wall-to-wall width. A pen of the foregoing construction and having its parts dimensioned as above stated may be completely filled with approximately six filling strokes. Where the vent 72 is formed of the smaller dimension, the pen may be filled with fewer strokes but where the vent is of larger dimension, a greater number of strokes is necessary.

It will be understood that the foregoing dimensions may be varied somewhat without departing from our invention so long as the relationships and principles of our invention disclosed herein are substantially followed.

Proper feed of ink from the reservoir 12 to the nib slit 57 is insured by forming the several portions of the capillary ink path between the reservoir and nib slit with such dimensions as will cause ink to be drawn by capillary action into the several portions of the capillary feed path and stand in a continuous column from the reservoir to the nib slit. As an example of the size of the various ink passages constituting the feed which have been found suitable for effecting proper flow of the ink, the capillary feed duct 45 may have a width of around 0.006" in its rearward portion 45a and around 0.005" in its forward portion 45b, the annular space 64 may have a radial thickness of around 0.006", the arcuate space 63 may have a radial thickness of around 0.0055", the capillary space 65 above the nib may have a width or thickness of around 0.005", and the feed slit 70 may have a width of around 0.007", although this dimension may be smaller. The nib slit 57 has the smallest capillary dimension and preferably is from 0.001" to 0.0015" in width to insure that ink is drawn therein and maintained therein at all times. The capillary cells are of greater cross-sectional dimension and lesser capillarity than the feed duct 45 with which they communicate so that ink will be drawn therefrom and into the feed duct whenever any ink is in the cells during the time the pen is

used in writing so that the cells are emptied by writing out.

From the foregoing, it will be seen that the present invention provides a multiple-stroke filling means which is simple in construction and highly efficient in operation. The provision of the very small internal diameter breather tube decreases the amount of ink which is displaced during the compression stroke, thereby increasing the efficiency of filling. At the same time by reason of the small internal diameter of the tube, a large proportion of the ink drawn into the pen in each suction stroke enters the reservoir.

The novel proportioning and arrangement of the vent which is located in the forward end of the breather tube provides the desired so-called "airplane" characteristic without materially decreasing the efficiency of the filling operation. Moreover, the arrangement is such that while it substantially prevents any decrease in the efficiency of the filling operation, on the other hand it does not impair the effectiveness of the venting function necessary to prevent expulsion of ink from the pen.

By forming the breather tube of silver or its equivalent, a number of advantages are obtained in addition to those just above-mentioned. The tube may be formed of very thin-walled stock and thus even though the vent opening may be made with a small diameter it may nevertheless be made very short in axial length relative to its diameter. Accordingly, the tendency for a film to form across the vent is substantially eliminated. In addition the highly wettable nature of the tube walls further inhibits the formation of such film. Moreover, silver may be readily fabricated and does not deteriorate over a long period of use and does not contaminate ordinary inks.

We claim:

1. A fountain pen comprising an ink reservoir, a pen nib, feed means defining a feed passage connecting the interior of said reservoir and said nib, and filling means for displacing air from said reservoir including a breather tube fixed relatively to said feed means and communicating at its forward end with said feed passage intermediate the ends thereof and exteriorly of said reservoir and at its rearward end with the interior of said reservoir for venting air from said reservoir, said breather tube having a continuously open lateral vent in its forward portion and intermediate its ends, and means defining a restricted passage opposite said vent providing communication between said vent and the interior of said reservoir, said restricted passage being of sufficiently small wall-to-wall width to cause substantial turbulence of air therein upon actuation of said filling means and consequent displacement of air through said breather tube and thereby prevent substantial flow of air through said vent.

2. A fountain pen comprising an ink reservoir, a pen nib, feed means defining a feed passage connecting the interior of said reservoir and said nib, and filling means for displacing ink from said reservoir including a breather tube fixedly secured relatively to said feed means and communicating at its forward end with said feed passage exteriorly of said reservoir and at its rearward end with the interior of said reservoir, for venting air from said reservoir, said breather tube being provided with a continuously open lateral vent in its forward portion providing communication between the interior of said tube and said reservoir and having a diameter smaller than

the internal diameter of said breather tube but substantially larger than the wall thickness of said breather tube and wall means defining a restricted passage surrounding the vented portion of said breather tube and opening into said reservoir.

3. A fountain pen comprising an ink reservoir, a pen nib, feed means including a governor having capillary ink storage spaces, said feed means defining a feed passage connecting the interior of said reservoir and said nib and connected to said spaces, and a breather tube communicating at its forward end with said feed means exteriorly of said reservoir and at its rearward end with the interior of said reservoir for venting air from said reservoir and having a side vent in its forward portion communicating with said reservoir, said governor and breather tube forming a well opening into said reservoir and receiving the vented portion of said breather tube to limit the flow of air from said vent during filling, said breather tube being formed of silver and providing surfaces which exhibit a relatively high degree of wettability with liquid inks.

4. A fountain pen comprising an ink reservoir, a pen nib, feed means defining a feed passage connecting the interior of said reservoir and said nib, a breather tube communicating at its forward end with said feed exteriorly of said reservoir and at its rearward end with the interior of said reservoir, said breather tube having an external diameter of around 0.046", an internal diameter of around 0.036", a lateral vent in the forward portion of said breather tube of from around 0.014" to around 0.026" in diameter, and means defining a restricted passage of around 0.026" wall-to-wall width opposite the vented portion of said breather tube and connecting said vent and the interior of said reservoir.

5. A fountain pen comprising an ink reservoir, a pen nib, feed means defining a feed passage connecting the interior of said reservoir and said nib and including a feed member in the forward portion of said reservoir, a breather tube of substantially uniform diameter fixed at its forward end in said feed member and extending rearwardly in said reservoir with the forward end of said breather tube communicating with said feed passage exteriorly of said reservoir and the rear end opening into said reservoir, said breather tube having a lateral vent adjacent its forward end and said feed member having a bore defining a well surrounding the vented portion of said breather tube and providing a restricted passage from said vent to the interior of said reservoir.

6. A fountain pen comprising means defining an ink reservoir and including a hollow body member, a pen nib, feed means defining a feed passage connecting the interior of said reservoir and said nib and including a feed member having a shank seated in the forward end of said hollow body member and formed with a bore communicating with said feed passage and opening at its rearward end into the interior of said reservoir, and a breather tube extending into said bore and fixedly seated therein with the forward end of said tube opening into said bore forwardly of said seat and the rearward end opening into the interior of said reservoir, the portion of said bore rearwardly of said seat being spaced from the corresponding portion of said breather tube and providing a restricted passage opening into said reservoir space, said breather tube having a lateral vent opening into said restricted passage intermediate the ends thereof.

15

7. In a fountain pen, means forming an ink reservoir, an ink feed means having a wall forming a trap or well connected to said reservoir, and filling mechanism including a silver breather tube with one end passing through said trap and connected to said feed means and the other end projecting toward the rear end of said reservoir, said breather tube being thin-walled with a small internal diameter and having a vent opening in that portion of said tube passing through said trap of less diameter than the internal diameter of the corresponding portion of said tube but greater than the wall thickness of the tube.

8. In a fountain pen, a writing nib, means forming an ink reservoir, an ink feed means including a well or trap directly connected to said reservoir and a feed passage connecting said well to said nib, and filling mechanism including a breather tube of uniform diameter having one end passing through said trap and connected to said feed means intermediate the ends of said feed passage and the other end projecting near the rear end of said reservoir, said breather tube

16

being thin-walled with a small internal diameter and formed of silver, said tube also having a small vent opening at a point located in said trap and discharging laterally thereinto.

MARLIN S. BAKER.
HARLAN H. ZODTNER.

REFERENCES CITED

The following references are of record in the file of this patent:

UNITED STATES PATENTS

Number	Name	Date
723,726	Perks et al. -----	Mar. 24, 1903
2,375,770	Dahlberg -----	May 15, 1945
2,398,521	Cloutier -----	Apr. 16, 1946
2,428,863	Wing -----	Oct. 14, 1947
2,521,657	Severy -----	Sept. 5, 1950

FOREIGN PATENTS

Number	Country	Date
3,451	Great Britain -----	Dec. 24, 1862
325,142	Italy -----	Mar. 1, 1935